



*We Speak DIESEL...since 1971*

**800-343-7351**

## **CONTRACTOR SERVICE - Diesel Trash Pumps**

Diesel America West's heavy service, self priming, centrifugal pumps feature quality usually found in more expensive units. As superstars in the pump world, these pumps are assembled using the finest components available. The Yanmar "L" series diesel, a popular and proven lightweight 4-cycle air cooled engine, is coupled to the super tough trash pump.

Together these units combine to make a serious high performance diesel general service pump that provides the user with easy starting, reliable service, excellent fuel economy, with engine and pump life many times greater than gasoline powered units!



### **Special Features**

- Tig welded, 1" stainless steel, #304 square tube roll cage frame
- Variable speed governor allowing pump speed to match the job
- Quick release stainless steel housing clamp for fast, easy cleanouts
- Long life oil-resistant heavy service rated internal parts with built-in check valve
- Easy recoil starting with auto compression release and self fuel bleed Extra tough anti-vibration isolator, and nonskid feet
- All in all, a lightweight, rugged, diesel pump that works and doesn't break!

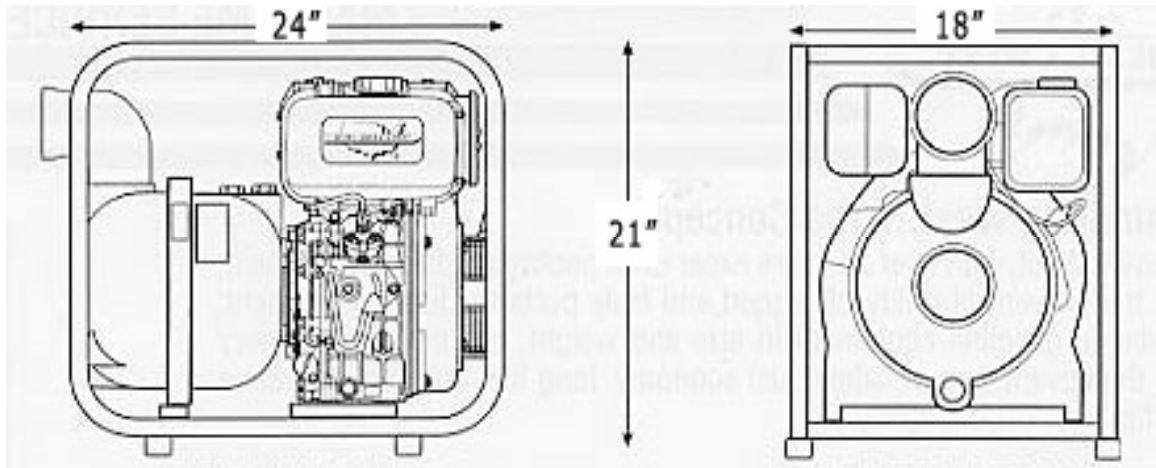

<b>PUMP SPECIFICATIONS</b>		
<b>Loadstar Model</b>	DPL48-2PT-2"	DPL70-3PT-3"
<b>Suction &amp; discharge</b>	2" FEM-NPT	3" FEM-NPT
<b>Maximum flow</b>	210 GPM	400 GPM
<b>Total dynamic head (max)</b>	98 FT	94 FT
<b>Suction lift (max.)</b>	26 FT	25 FT
<b>Spherical solids (in.)</b>	1"	1.75"
<b>Seal, main (bellows type)</b>	Silicon carbide	
<b>Main pump shaft</b>	Stainless steel sleeve	
<b>Housing, corrosion proof</b>	Glas/poly	
<b>Impeller (non-spark)</b>	High performance 636	
<b>ENGINE SPECIFICATIONS</b>		
<b>Model</b>	Yanmar L 48 AE	Yanmar L 70 AE
<b>Combustion system</b>	Direct Injection	
<b>Displacement cc (cu.in.)</b>	211 (12.88)	296 (18.06)
<b>Bore x stroke mm (in.)</b>	70X55 (2.76X2.17)	78X62 (3.07X2.44)
<b>Engine speed maximum</b>	3600	3600
<b>Output HP</b>	4.7	6.7
<b>Continuous output HP</b>	4.2	6.0
<b>Dry weight kilos (lbs)</b>	26 (57)	33 (73)
<b>Fuel tank cap. L. (gal.)</b>	3.5 (0.92)	3.5 (0.92)
<b>Lube oil cap. L. (gal.)</b>	0.8 (0.21)	1.1 (0.29)
<b>DIMENSIONS</b>		
<b>Dry weight (pounds)</b>	97	118
<b>Length</b>	24"	
<b>Width</b>	18"	
<b>Height</b>	21"	

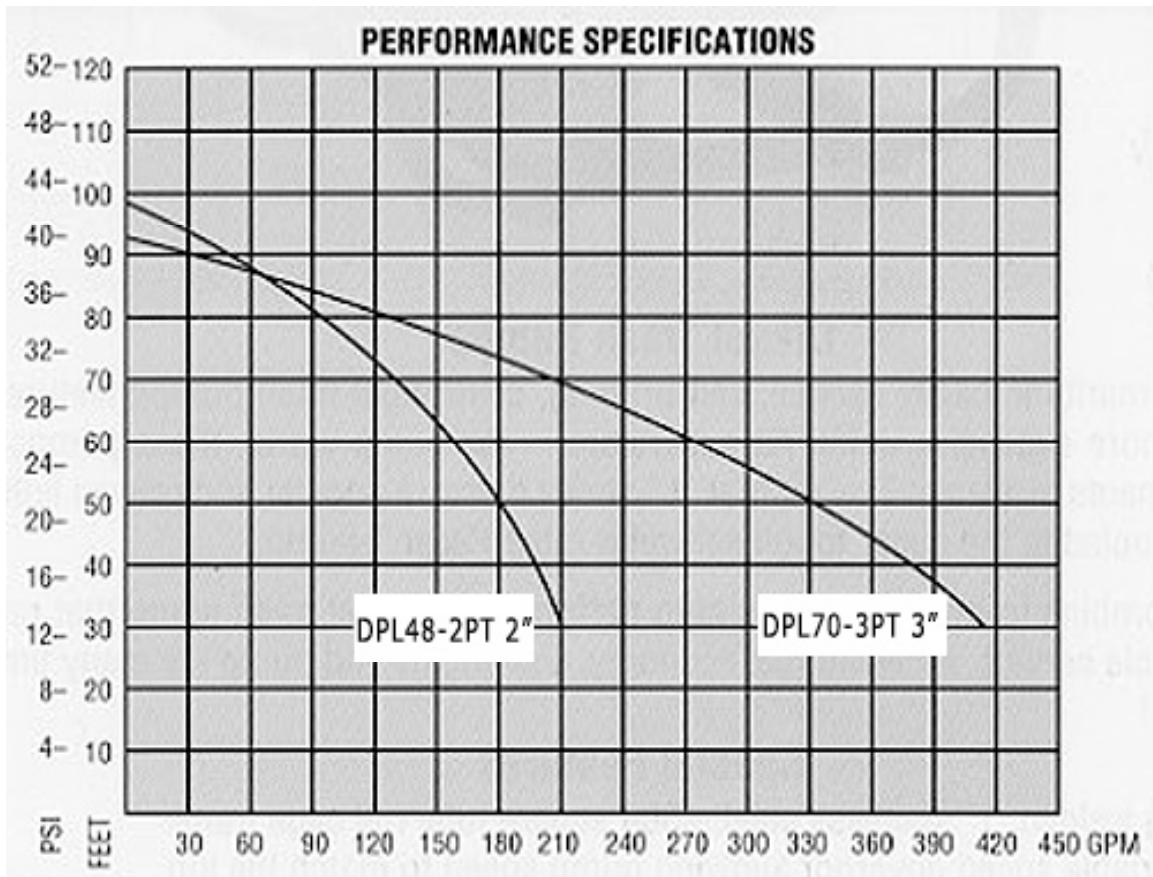

**Call or write us today for more information!**

Contact us at:

**Diesel America West**  
 Post Office Box 968  
 Friday Harbor, WA 98250

800-DIESEL-1 • 360-378-4182 • FAX: 360-378-3315

[dawest@rockisland.com](mailto:dawest@rockisland.com)

Manufacturers of Quality Diesel Equipment

[www.dawest.com](http://www.dawest.com)