



We Speak DIESEL...since 1971

800-343-7351

SLURRY / SLUDGE SERVICE - Diesel Diaphragm Pumps

Diesel America West's heavy service, self priming, diaphragm slurry/sludge pumps feature quality usually found in heavier and more expensive units. As superstars in the pump world, these pumps are assembled using the finest components available. The Yanmar "L" series diesel, a popular and proven lightweight 4-cycle air cooled engine, is coupled to the super tough, gear reduction, cast aluminum diaphragm pump. Use these pumps for sandy, muddy, slurry water-industrial waste, septic tanks, environmental cleanup and other tough jobs!



Together these units combine to make a serious high performance diesel diaphragm pump that provides the user with easy starting, reliable service, excellent fuel economy, with engine and pump life many times greater than gasoline powered units!

Special Features

- **Heavy duty cast aluminum pump housing with gear reduction drive**
- **Variable speed governor allowing pump speed to match the job**
- **Fast, sure self-priming, self-cleaning water flow through internal valves**
- **High suction lift with dry prime capability**
- **Pump can run dry without damage**
- **Easy recoil starting with auto decompression release and self fuel bleed**
- **Heavy service trolley with rubber tires and convenient handle**
- **All in all, a lightweight, rugged, diesel pump that works and doesn't break**

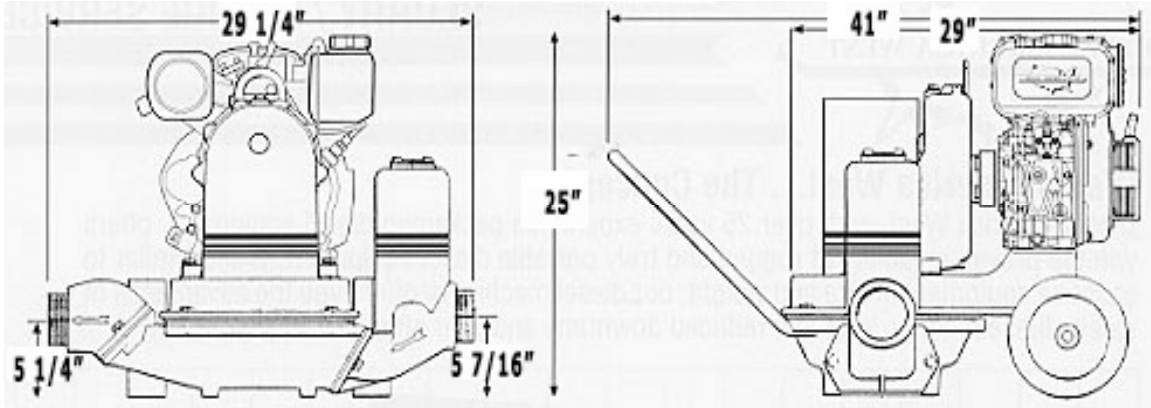

PUMP SPECIFICATIONS		
Loadstar Model	DPL48-D2	DPL48-D3
Model size	2"	3"
Suction & discharge	2" MALE-NPT	3" MALE-NPT
Maximum flow	86 GPM	100 GPM
Maximum discharge head		25 FT
Maximum suction lift		26 FT
Maximum spherical solid	1.5"	1.75"
Bearings	Ball	
Diaphragm & valves	Rubber, TPE Neoprene, Buna or Viton	
Housing	Heavy cast aluminum	
ENGINE SPECIFICATIONS		
Model	Yanmar L 48 AE	
Combustion system	Direct Injection	
Displacement cc (cu.in.)	211 (12.88)	
Bore x stroke mm (in.)	70X55 (2.76X2.17)	
Engine speed maximum	3600	
Max. horsepower	4.8	
Continuous output HP	4.2	
Dry weight kilos (lbs)	26 (57)	
Fuel tank cap. L. (gal.)	3.5 (0.92)	
Lube oil cap. L. (gal.)	0.8 (0.21)	
DIMENSIONS		
Dry weight (pounds)	152	160
Length	41"	
Width	29 1/4"	
Height	25"	

Performance Specifications

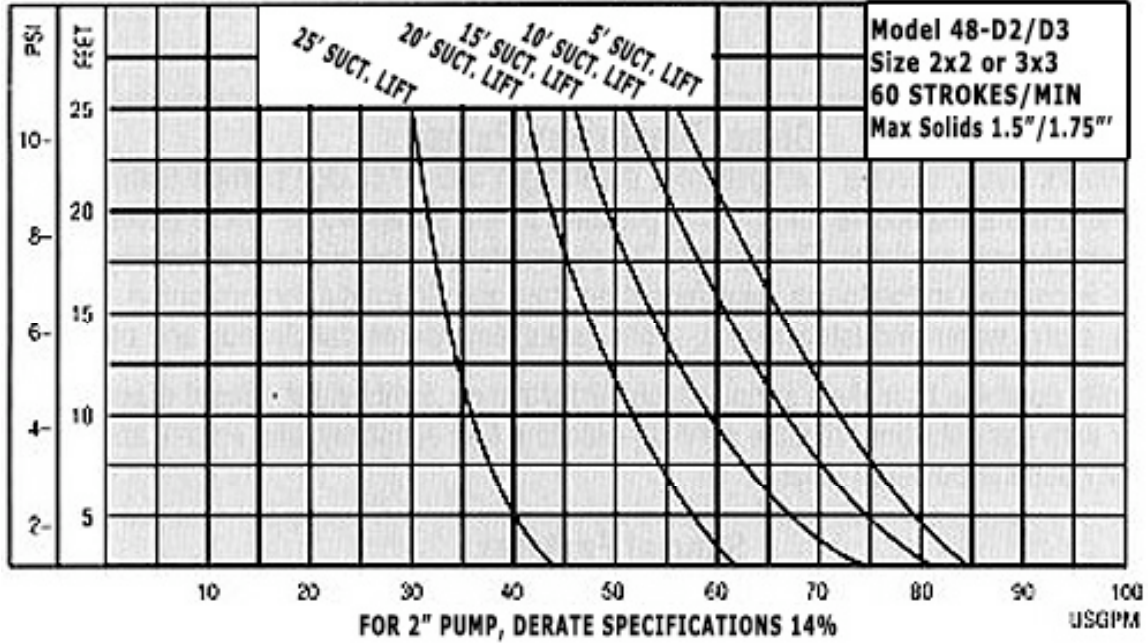

Call or write us today for more information!

Contact us at:

Diesel America West
Post Office Box 968
Friday Harbor, WA 98250

800-DIESEL-1 • 360-378-4182 • FAX: 360-378-3315

dawest@rockisland.com

Manufacturers of Quality Diesel Equipment

www.dawest.com